

Low-Cost Monolithic Quad SPST CMOS Analog Switches

Features

- $\pm 15\text{-V}$ Analog Signal Range
- TTL Compatibility
- Logic Inputs Accept Negative Voltages
- On-Resistance— $r_{DS(on)}$: $115\ \Omega$

Benefits

- Wide Signal Range
- Simple Logic Interface
- Reduced Power Consumption

Applications

- Disk Drives
- Test Equipment
- Communication Systems
- Sample-and-Holds

Description

The DG211 and DG212 are low cost quad single-pole single-throw analog switches for use in general purpose switching applications in communication, instrumentation and process control. These devices differ only in that the digital control logic is inverted (see Truth Table). The use of both p- and n-channel devices minimizes on-resistance variation over the analog signal range.

voltage rating of 40 V, both switches will handle $\pm 15\text{-V}$ input signals with ease, and have a continuous current rating of 20 mA. An epitaxial layer prevents latchup.

Both devices feature true bi-directional performance (with no offset voltage) in the on condition, and will block signals to 30 V peak-to-peak in the off condition.

Designed with the Siliconix PLUS-40 CMOS process to combine low power dissipation with a high breakdown

For new designs we recommend the silicon-gate DG211B/212B upgrades.

Functional Block Diagram and Pin Configuration

DG211

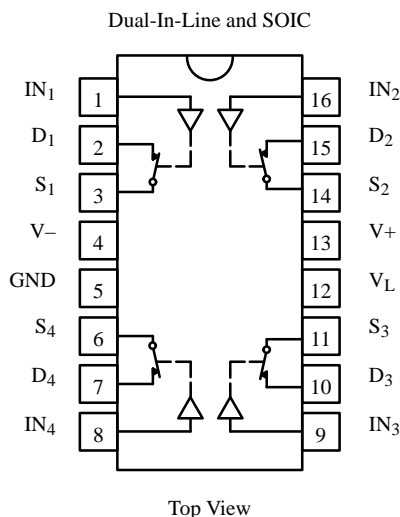

Truth Table

Logic	DG211	DG212
0	ON	OFF
1	OFF	ON

Logic "0" $\leq 0.8\text{ V}$
Logic "1" $\geq 2.4\text{ V}$

Ordering Information

Temp Range	Package	Part Number
0°C to 70°C	16-Pin Plastic DIP	DG211CJ
		DG212CJ
-40°C to 85°C	16-Pin Narrow SOIC	DG211DY
		DG212DY

Updates to this data sheet may be obtained via facsimile by calling Siliconix FaxBack, 1-408-970-5600. Please request FaxBack document #70039.

Absolute Maximum Ratings

V ₊ to V ₋	44 V
V _{IN} to GND ^a	V ₋ , V ₊
V _L to GND	-0.3 V, 25 V
V _S or V _D to V ₊ ^a	0, -40 V
V _S or V _D to V ₋ ^a	0, 40 V
V ₊ to GND	25 V
V ₋ to GND	-25 V
Current, Any Terminal Except S or D	30 mA
Continuous Current, S or D	20 mA
Peak Current, S or D (Pulsed at 1 ms, 10% duty cycle max)	70 mA

Storage Temperature	-65 to 125°C
Power Dissipation (Package) ^b	
16-Pin Plastic DIP ^c	470 mW
16-Pin Narrow SOIC ^d	600 mW

Notes:

- Signals on S_X, D_X, or IN_X exceeding V₊ or V₋ will be clamped by internal diodes. Limit forward diode current to maximum current ratings.
- All leads welded or soldered to PC Board.
- Derate 6.5 mW/°C above 25°C
- Derate 7.6 mW/°C above 75°C

Specifications

Parameter	Symbol	Conditions Unless Otherwise Specified V ₊ = 15 V, V ₋ = -15 V V _{IN} = 2.4 V, 0.8 V ^e	Temp ^a	Limits			Unit	
				Min ^c	Typ ^b	Max ^c		
Analog Switch								
Analog Signal Range ^d	V _{ANALOG}		Full	-15		15	V	
Drain-Source On-Resistance	r _{DS(on)}	I _S = 1 mA, V _D = ±10 V	Room Full		115	175 250	Ω	
Source Off Leakage Current	I _{S(off)}	V _S = ±14 V, V _D = ∓14 V	Room Full	-5 -100	±0.02	5 100	nA	
Drain Off Leakage Current	I _{D(off)}		Room Full	-5 -100	±0.02	5 100		
Drain On Leakage Current	I _{D(on)}	V _S = V _D = ±14 V	Room Full	-5 -200	±0.15	5 200		
Digital Control								
Input Current Input Voltage High	I _{INH}	V _{IN} = 2.4 V	Room Full	-1 -10	-0.0004		μA	
		V _{IN} = 15 V	Room Full		0.003	1 10		
Input Current Input Voltage Low	I _{INL}	V _{IN} = 0 V	Room Full	-1 -10	-0.0004			
Dynamic Characteristics								
Turn-On Time	t _{ON}	See Switching Time Test Circuit, V _S = 2 V	Room			460	1000	ns
Turn-Off Time	t _{OFF1}		Room			360	500	
	t _{OFF2}		Room			450	450	
Source-Off Capacitance	C _{S(off)}	V _S = 0 V, V _{IN} = 5 V, f = 1 MHz	Room			5		pF
Drain-Off Capacitance	C _{D(off)}		Room			5		
Channel On Capacitance	C _{ON}	V _D = V _S = 0 V, V _{IN} = 0 V, f = 1 MHz	Room			16		
Off Isolation	OIRR	V _{IN} = 5 V, R _L = 1 kΩ C _L = 15 pF, V _S = 1 V _{RMS} , f = 100 kHz	Room			70		dB
Channel-to-Channel Crosstalk	X _{TALK}		Room			90		

Specifications

Parameter	Symbol	Conditions Unless Otherwise Specified $V_+ = 15\text{ V}, V_- = -15\text{ V}$ $V_{IN} = 2.4\text{ V}, 0.8\text{ V}^e$	Temp ^a	Limits			Unit
				Min ^c	Typ ^b	Max ^c	
Power Supplies							
Positive Supply Current	I_+	$V_{IN} = 0\text{ or }5\text{ V}$	Room		0.35	0.48	mA
Negative Supply Current	I_-		Room		0.3	0.48	
Logic Supply Current	I_L		Room		0.5	1.2	

Notes:

- Room = 25°C, Full = as determined by the operating temperature suffix.
- Typical values are for DESIGN AID ONLY, not guaranteed nor subject to production testing.
- The algebraic convention whereby the most negative value is a minimum and the most positive a maximum, is used in this data sheet.
- Guaranteed by design, not subject to production test.
- V_{IN} = input voltage to perform proper function.

Typical Characteristics

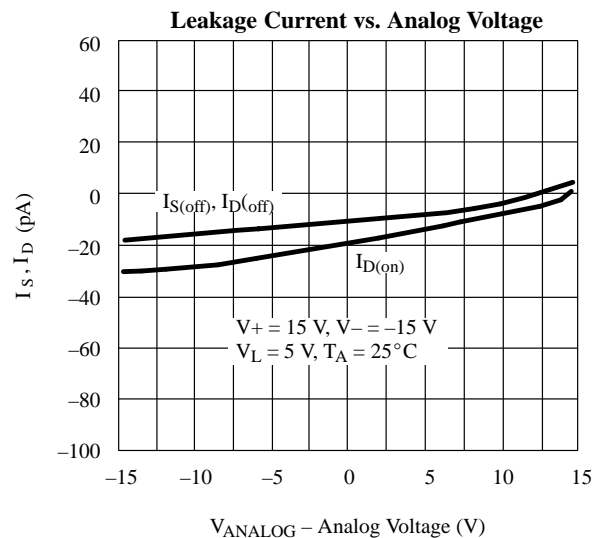
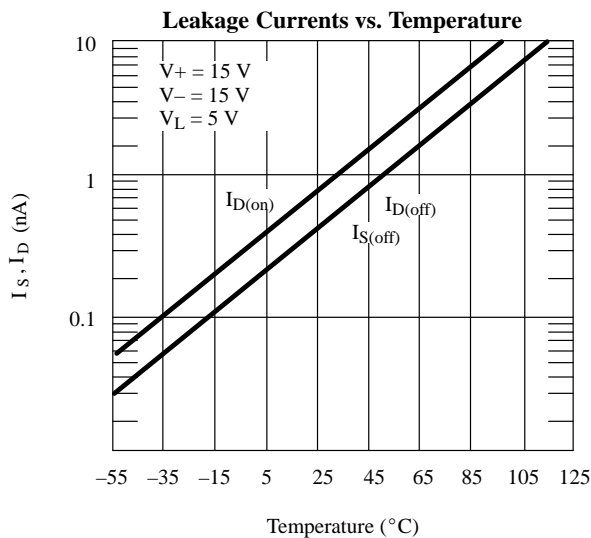
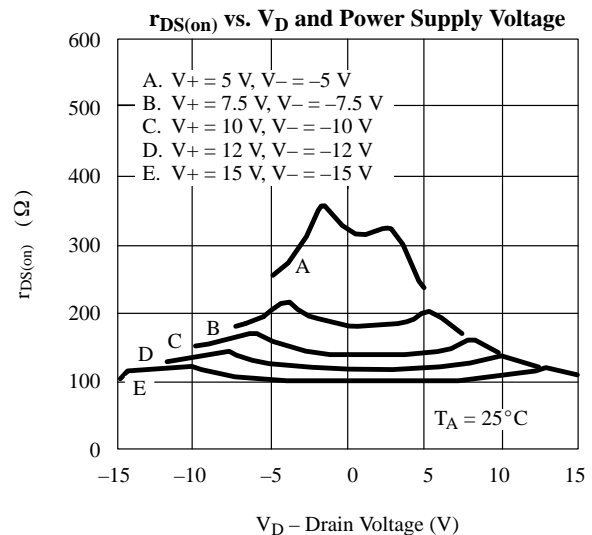
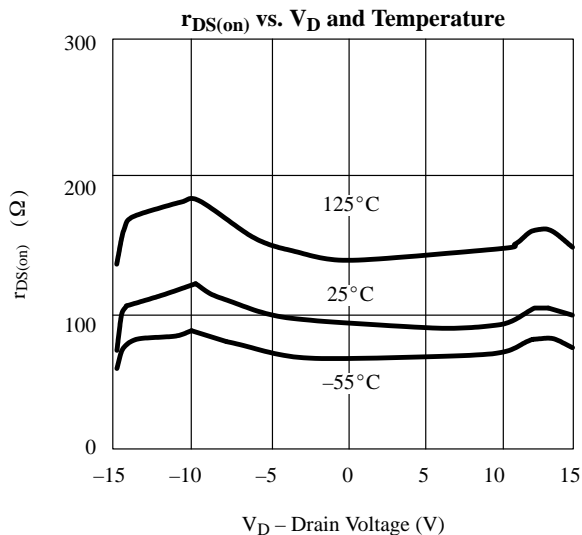

Typical Characteristics

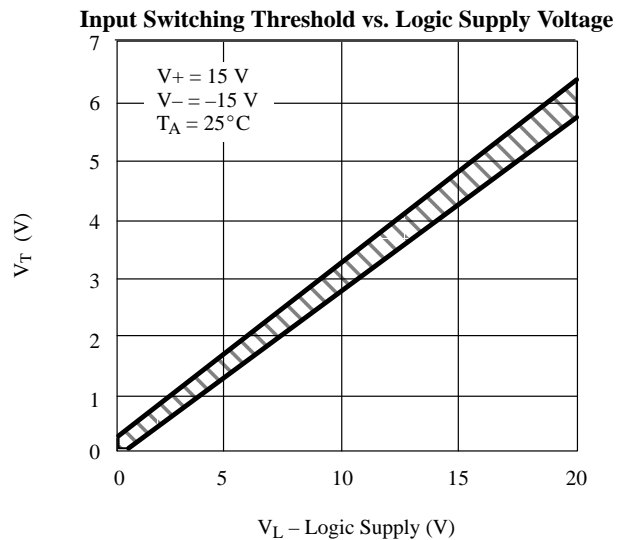
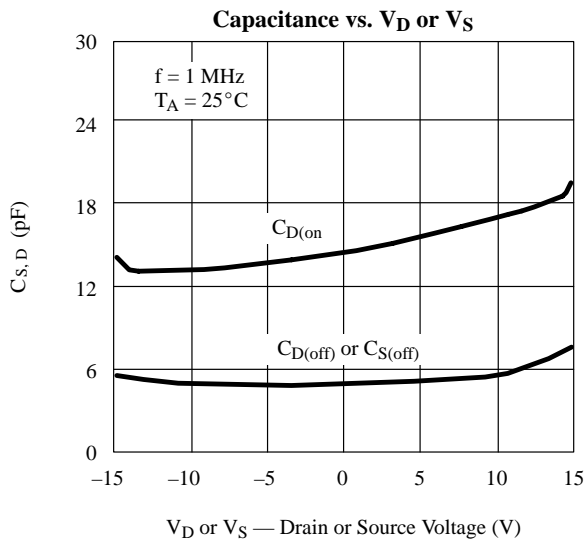
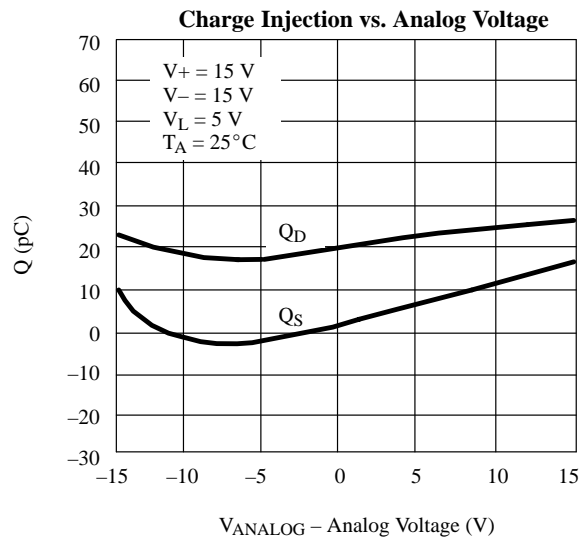
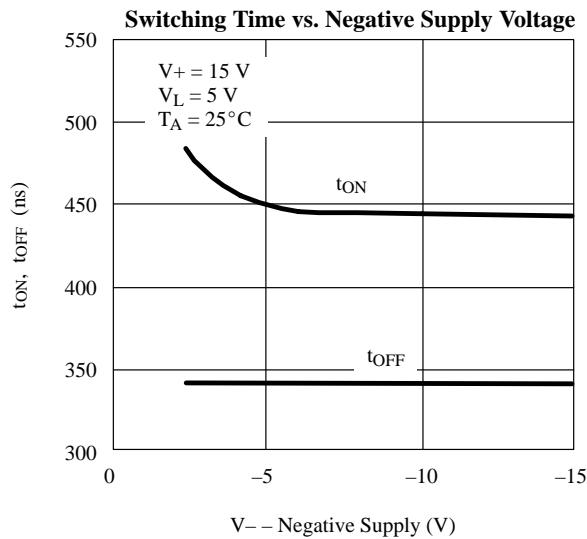
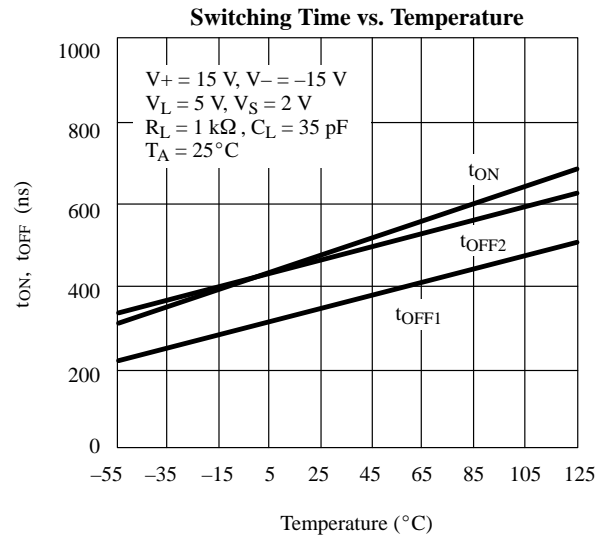
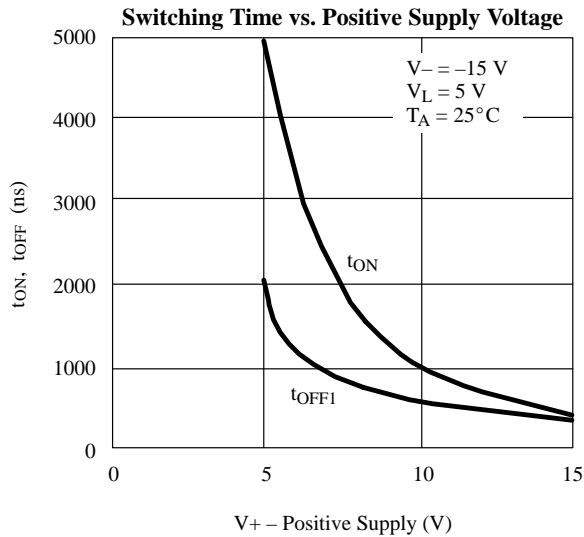

Typical Characteristics

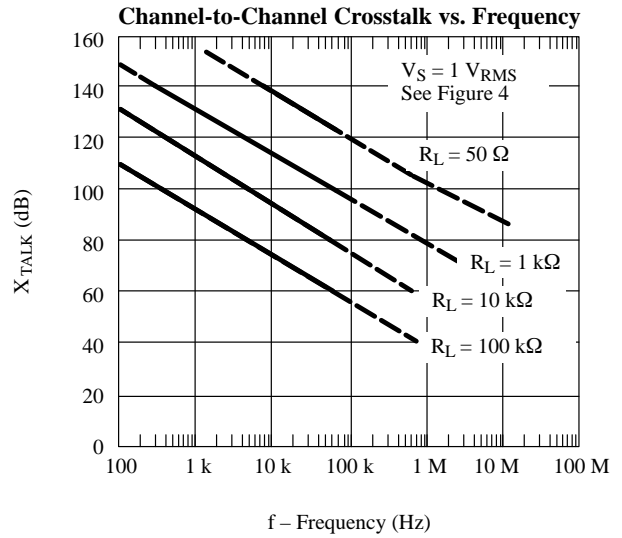
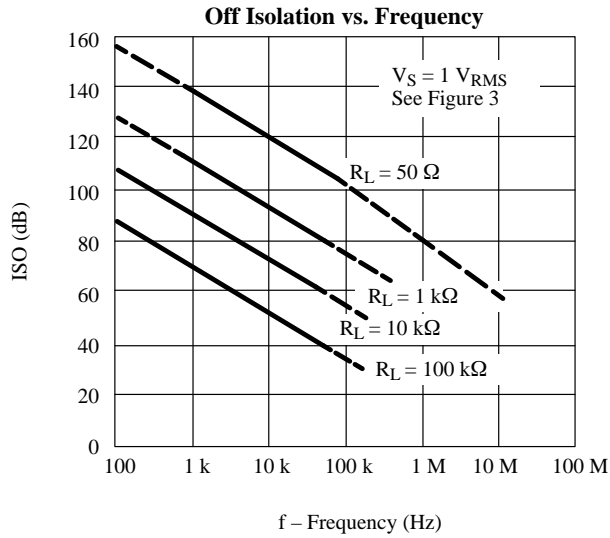

Schematic Diagram (Typical Channel)

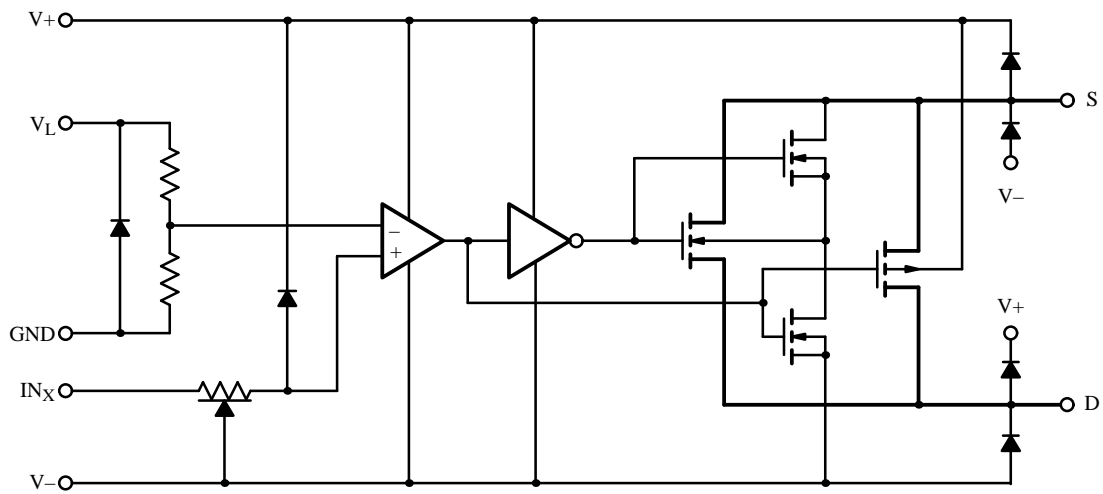
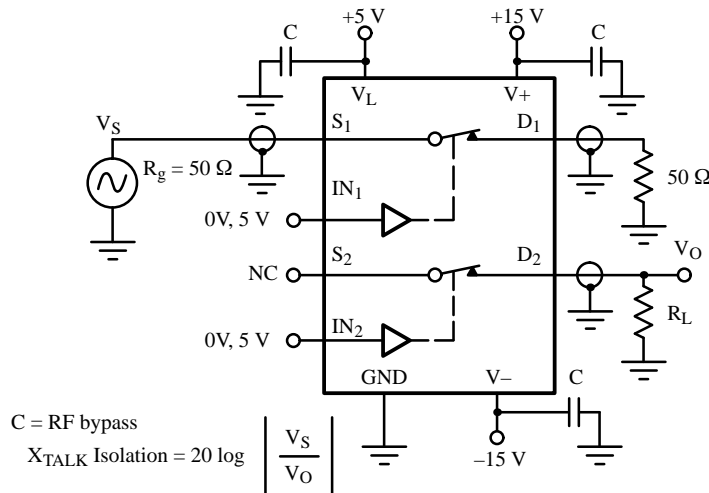
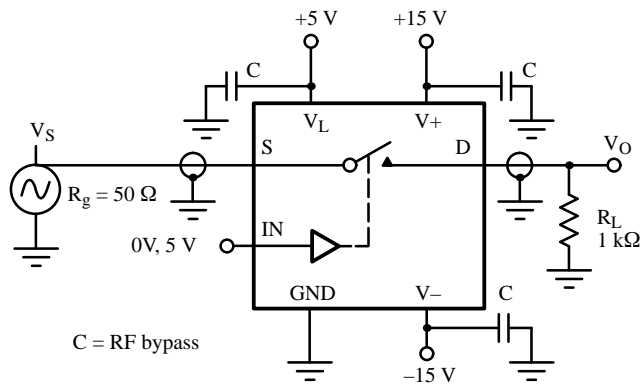
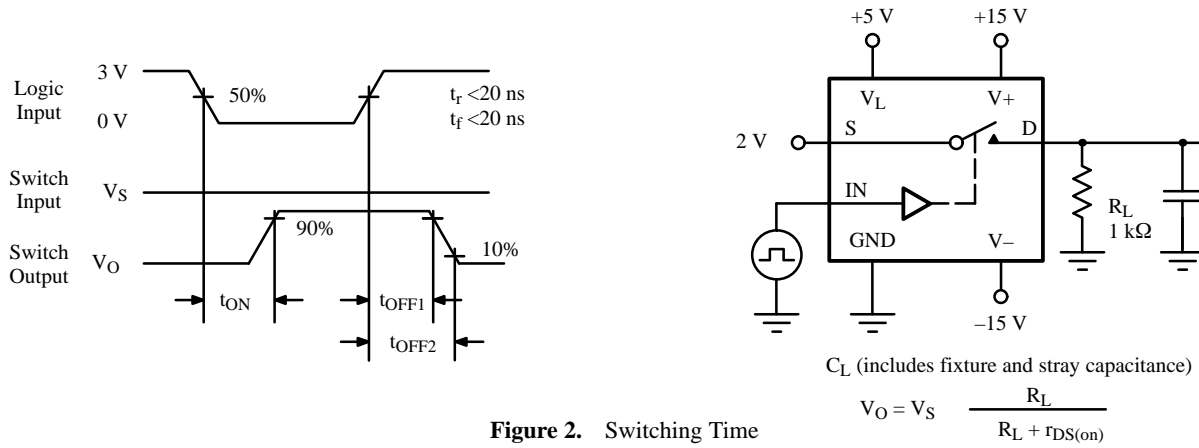

Figure 1.

Test Circuits

V_O is the steady state output with the switch on. Feedthrough via switch capacitance may result in spikes at the leading and trailing edge of the output waveform.



Applications Hints^a

Some applications of the DG211 or DG212 will find the logic control inputs IN_X driven from the output of comparators or op-amps with nearly plus to minus 15-V transitions. In these applications the user can shift the input

logic transition voltage from the normal 1.6 V of TTL to zero volts by connecting the V_L pin to the GND pin. In this mode of operation the input offset voltage between IN_X and $V_L (= GND)$ measures less than ± 500 mV.

V+ Positive Supply Voltage (V)	V- Negative Supply Voltage (V)	V _L Logic Supply Voltage (V)	V _{IN} Logic Input Voltage V _{INH(min)} /V _{INL(max)} (V)	V _S or V _D Analog Voltage Range (V)
20	-20	5	2.4/0.8	-20 to 20
15	-15	5	2.4/0.8	-15 to 15
12	-12	5	2.4/0.8	-12 to 12
10	-10	5	2.4/0.8	-10 to 10
8 ^b	-8	5	2.4/0.8	-8 to 8
10	-10	10	5/2	-10 to 10

Notes:

- Application Hints are for DESIGN AID ONLY, not guaranteed and not subject to production testing.
- Operation below ± 8 V is not recommended.

Applications

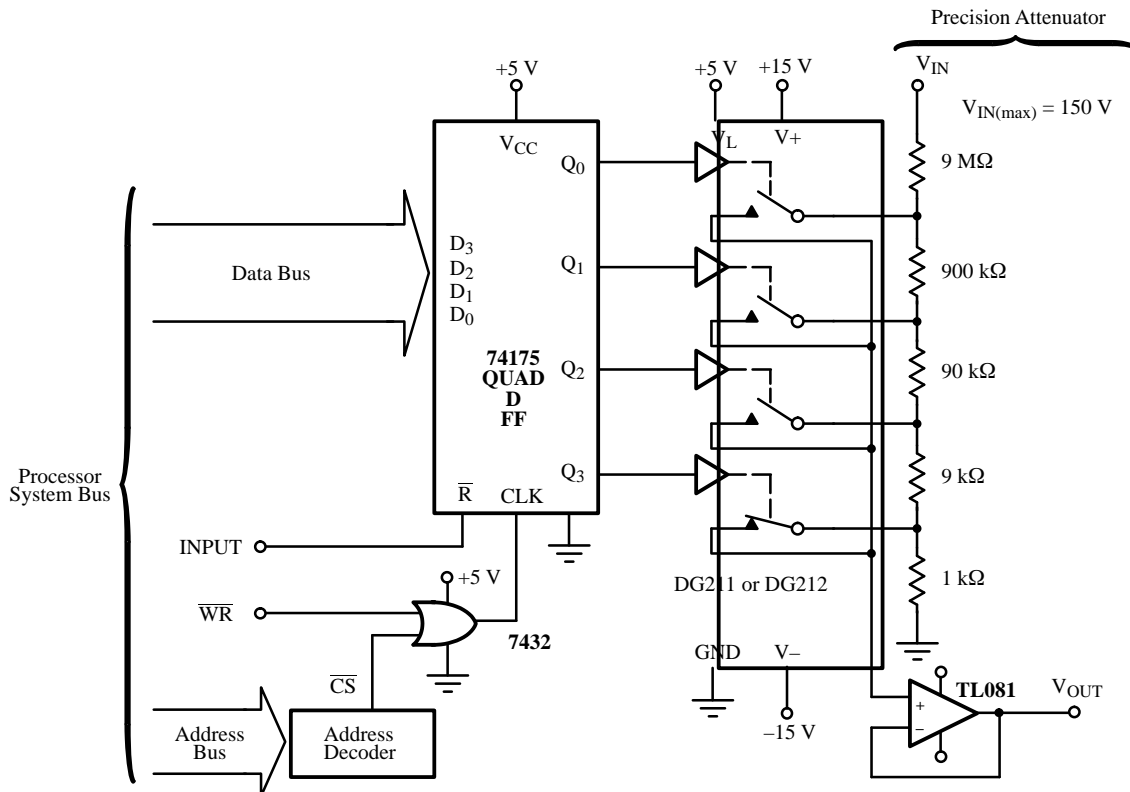

Figure 5. Microprocessor Controlled Analog Signal Attenuator

Applications (Cont'd)

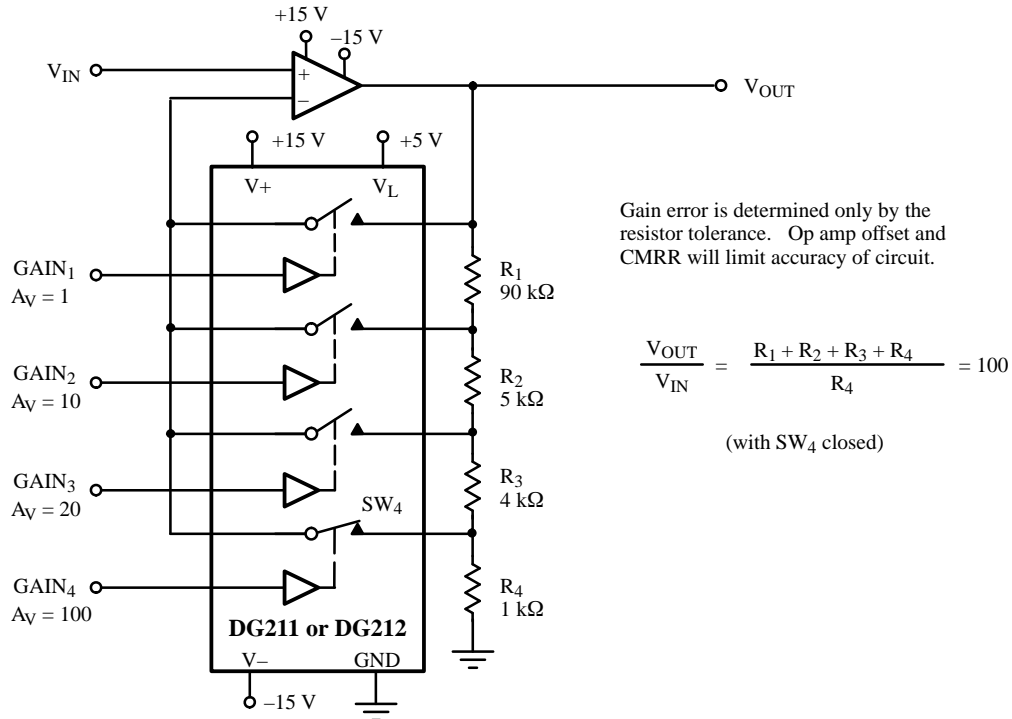

Figure 6. Precision-Weighted Resistor Programmable-Gain Amplifier

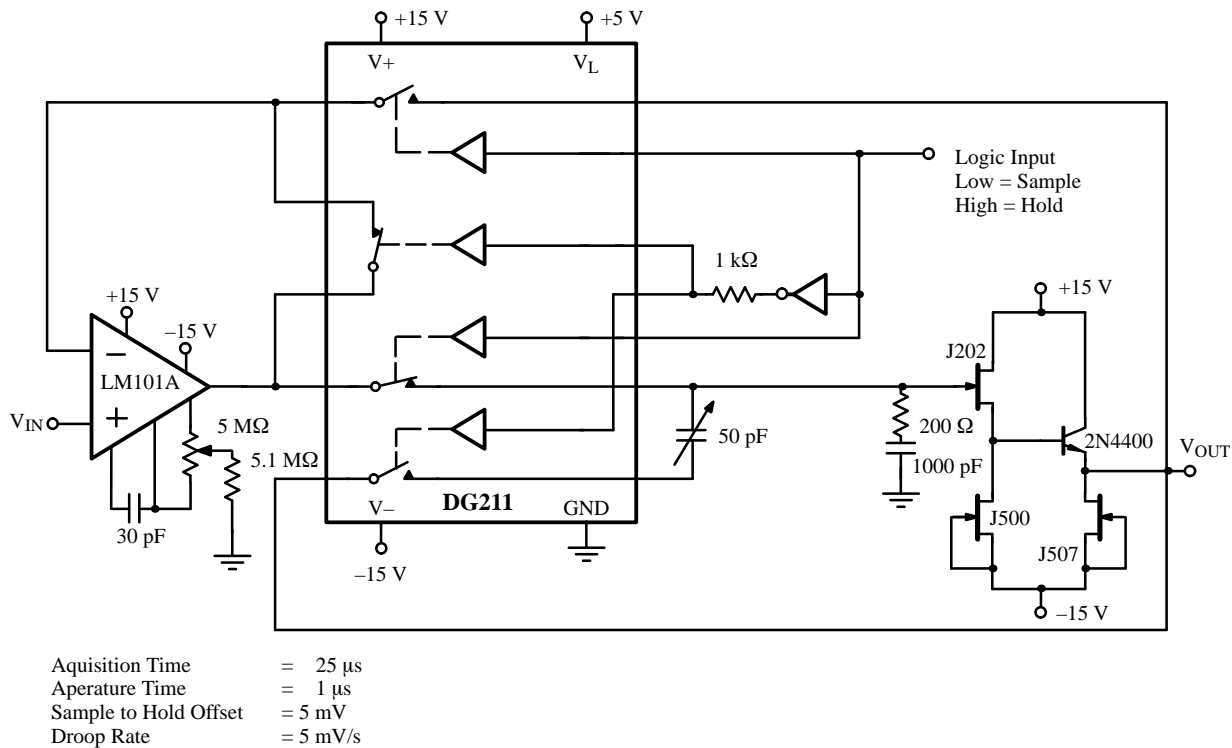
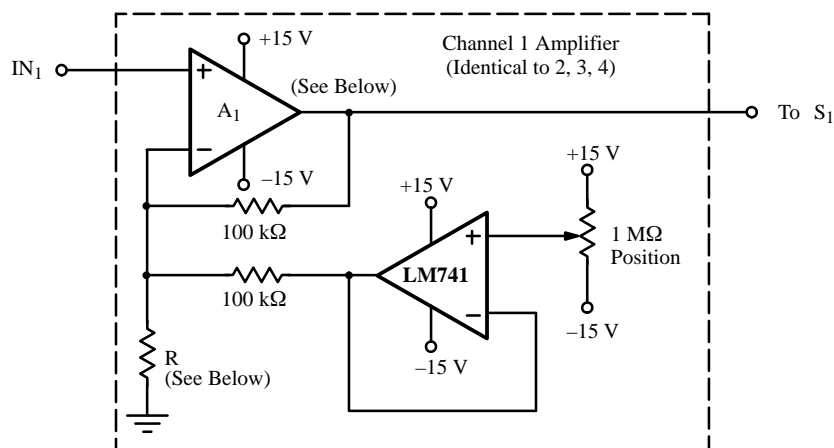
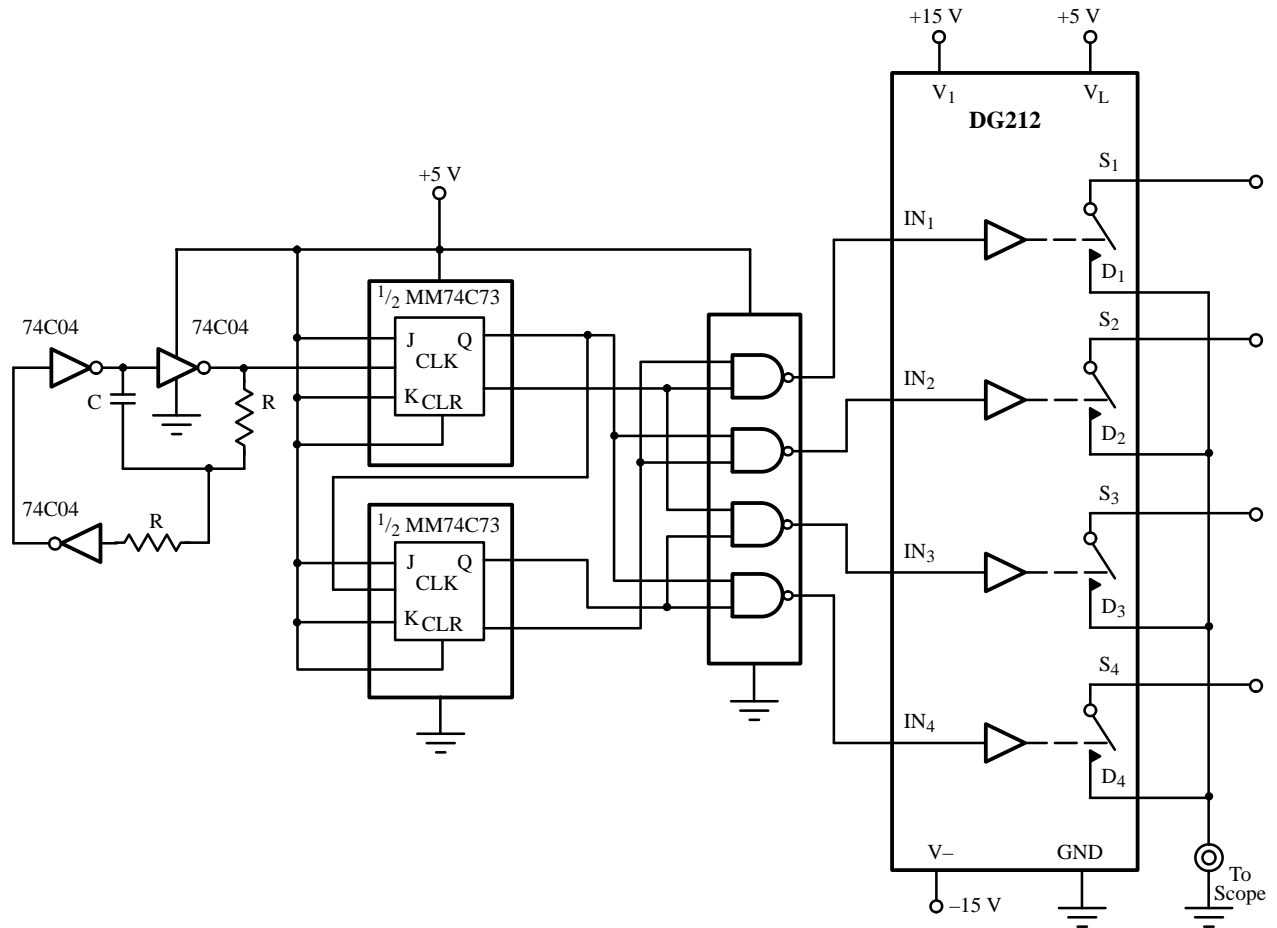

Figure 7. DG211 Sample-and-Hold

Applications (Cont'd)



A₁ is op amp with suitable bandwidth, slew rate, etc., for desired signals.
R is added for extra gain according to formula: Voltage Gain = $1 + \frac{100 \text{ k}\Omega}{R}$

Figure 8. The "Scope Extender" Which Displays 4-Channels Simultaneously on a Single Trace Scope